

INLGB04IRA

4.1 MP Vandal Proof Motorized Lens Bullet Network Camera w/IR, SD Slot

- Incredible 4MP Auto Focus Lens; ready-to-operate!
- H.265+ & H.264 encoding
- Smart IR, Up to 30 m (98ft) IR distance
- Smart Detection: Intrusion, Human Detection and more
- Supports Micro SD Card, up to 256GB



NDAA
Compliant

Unify your Security Solution

You asked, we listened. Tailored especially for you, Legend is our **fully NDAA compliant brand**. It offers our latest technologies in a robust build with edge storage capacity. Legend by Inaxsys provides H.265+ compression and easy installation.

Smart H.265+ & H.264+

LEGEND smart encoding technology provides high-quality video with higher efficiency and also reduces the cost of storage space and transmission bandwidth by adopting an advanced algorithm of auto stream control.

On-board Analytics

This camera responds accurately to specific events in a given area. Our algorithm enables Human detection, intrusion detection, motion detection and much more. Facilitate your viewing experience using on the edge analytics – one product, multiple features.



*Design and specifications are subjects to change without notice.



INLGB04IRA

4.1 MP Vandal Proof Motorized Lens Bullet Network Camera w/IR, SD Slot

Product Specifications

Camera					
Image Sensor	1/3", 4 Megapixel, progressive scan, CMOS				
Scanning System	Progressive				
Electronic Shutter Speed	Auto/Manual, 1~1/100,000 s				
Minimum Illumination	Color: 0.01 Lux (F1.6, AGC ON) 0 Lux with IR				
S/N Ratio	Less than 52				
IR Distance	Distance up to 30m (98ft)				
Camera Features					
Day/Night	IR-cut filter with auto switch (ICR)				
Backlight Compensation	Supported				
Noise Reduction	2D/3D DNR				
Features	HLC; BLC; DWDR				
Privacy Masking	Up to 4 areas				
OSD	Up to 4 OSDs				
Region of Interest	Up to 2 areas				
Motion Detection	Up to 4 areas				
Lens					
Lens Type	Motorized Lens				
Focal Length	2.8mm ~ 12mm				
Viewing Angle	H: 91.0° ~ 27°; V: 54.4° ~ 13.7°; O: 118.3° ~ 33.2°				
Pan/Tilt/Rotate	Pan: 0° ~ 360°; Tilt: 0 ~ 90°; Rotate: 0 ~ 360°				
DORI Distance	Lens (mm)	Detect (m)	Observe (m)	Recognize (m)	Identify (m)
	2.8	63.0	25.2	12.6	6.3
	12	270	108	54	27
Video					
Compression	H.265+, H.265, H.264, MJPEG				
H.264 code profile	Baseline Profile, Main Profile				
Frame Rate	Main Stream: 4MP (2592x1520), Max 20fps Sub Stream: 720P (1280x720): Max. 20 fps Third Stream: D1 (704x576): Max. 20 fps				
Smart Detetion					
Intelligent Search	Intrusion, Human Detection, Motion detection, Tampering alarm				
Intrusion	Entering and loitering in a pre-defined virtual region				

*Design and specifications are subjects to change without notice.



INLGB04IRA

4.1 MP Vandal Proof Motorized Lens Bullet Network Camera w/IR, SD Slot

Product Specifications

Network	
Ethernet	1 RJ45 100M Base-TX Ethernet
Protocol	IPv4, IGMP, ICMP, ARP, TCP, UDP, DHCP, RTP, RTSP, RTCP, DNS, DDNS, NTP, FTP, UPnP, HTTP, HTTPS, SMTP, SSL, QoS
Compatibility	ONVIF (Profile S, Profile G, Profile T), API
Storage	
Edge Storage	Micro SD card, up to 256GB
General	
Power Supply	DC 12V±25%, PoE (IEEE 802.3af)
Power Consumption	Less than 6.5W
Working Environment	-30°C to 60°C (-40°F to 140°F) / Less than 95% RH
Protection	IP67; IK10
Weight	2.2 lbs (1kg)
Dimensions	240.3 × 86.4 × 75.6mm (9.46" × 3.4" × 2.98")

*Design and specifications are subjects to change without notice.



INLGB04IRA

4.1 MP Vandal Proof Motorized Lens Bullet Network Camera w/IR, SD Slot

Product Specifications

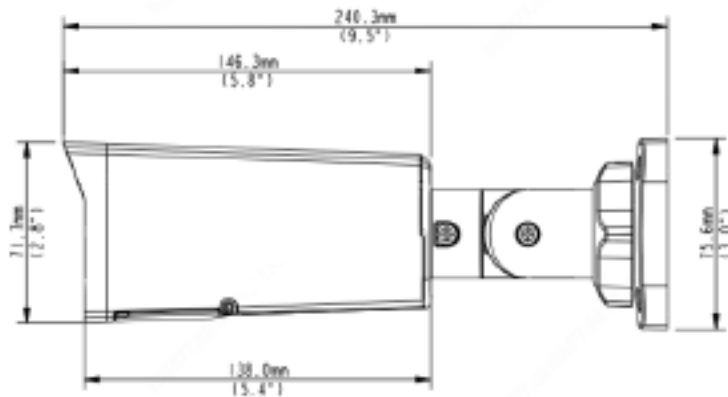
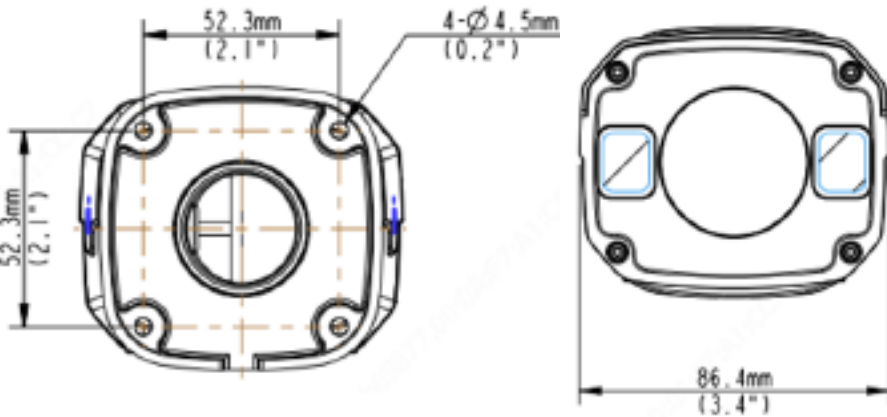

**XLGJB06-A
Junction Box**



**XLGJB06-A
Junction Box**



**XLGA01
Waterproof Joint**



**VUSD256G
Micro SD Card**



**XLGUP06-C
Pole Mount**

Optional



**XLGA01
Waterproof Joint**



**XLGUP06-C
Pole Mount**

*Design and specifications are subjects to change without notice.

